



STREAK™ 7

Quick Start Guide

About Notes



NOTE: A NOTE indicates important information that helps you make better use of your product.

Information in this document is subject to change without notice.

© 2011 Dell Inc. All rights reserved.

Dell™, the DELL logo, and Streak™ are trademarks of Dell Inc.; Microsoft® and Windows® are either trademarks or registered trademarks of Microsoft Corporation in the United States and/or other countries.

Other trademarks and trade names may be used in this manual to refer to either the entities claiming the marks and names or their products. Dell Inc. disclaims any proprietary interest in trademarks and trade names other than its own.

2011 - 08

P/N 0FNHM

Rev. A00

About Your Dell Streak 7 Tablet

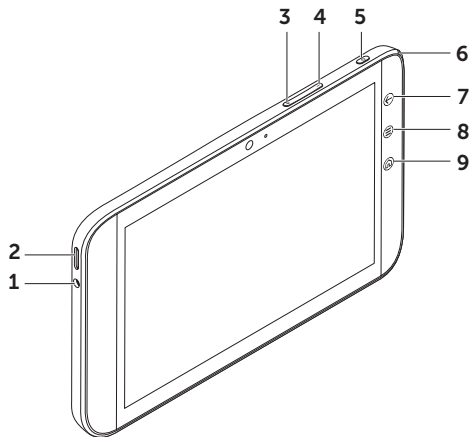

- 1 Headphone connector
- 2 Speaker
- 3 Volume-up button
- 4 Volume-down button
- 5 Power and Sleep/Wake button
- 6 Battery-status light
- 7 Back button (←)
- 8 Menu button (≡)
- 9 Home button (Ⓜ)

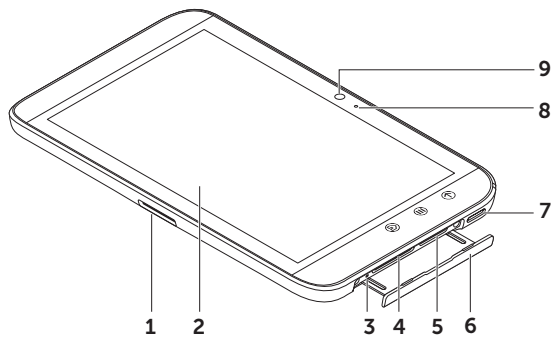

- 1 30-pin connector
- 2 Touch screen
- 3 Force power-off button
- 4 SD-card slot
- 5 SIM-card slot
(on 3G model only)
- 6 Slot door
- 7 Speaker
- 8 Microphone
- 9 Camera

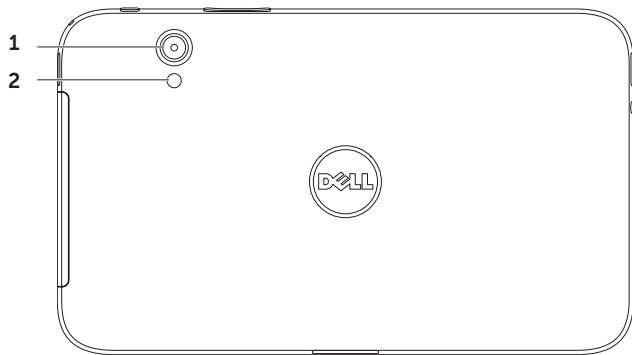

1 Camera

2 Flash

Set Up Your Dell Streak 7 Tablet

1. Insert the SD card (Optional)

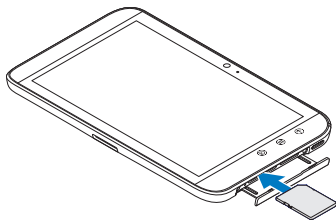

2. Insert the SIM card on 3G model (Optional)

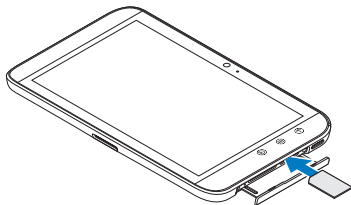

3. Charge the battery

Charge the battery of your tablet fully before using it for the first time.

The battery-status light indicates the following:

- Red — the battery is charging
- Green — the battery is fully charged

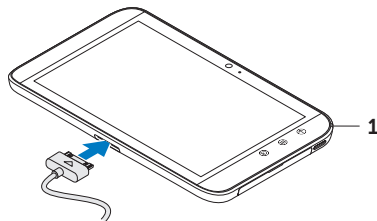

1 Battery status light

Turn on Your Tablet

Press and hold the power button to turn on your tablet.

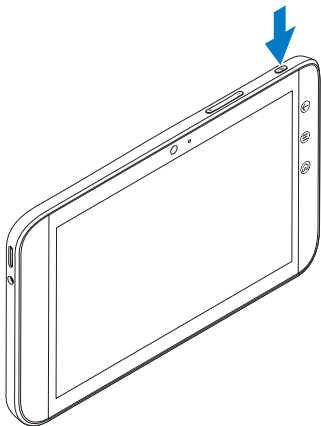

Connect a Headphone

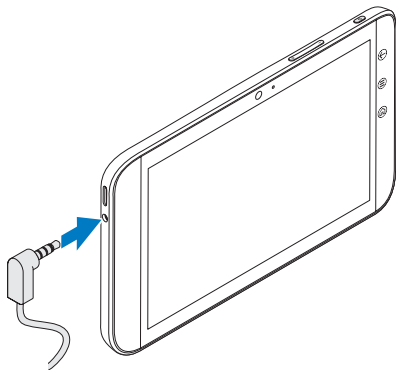

Connect the 3.5 mm headphone to the headphone connector.



Lock Screen

Your tablet enters sleep mode automatically after a preset duration of inactivity. To wake up your tablet from sleep mode, press the power button once. Touch and hold the lock icon  to turn it into a circle, and then drag the inner circle to the edge of the outer circle to unlock the screen.



To set the duration after which the tablet enters sleep mode, touch Home  → Launcher  → **Settings** → **Screen** → **timeout** and select the desired option.

Dell Stage

Your tablet has five customizable Home screens. To navigate across the Home screens, flick your finger to the right or left on the screen.



You can add the Dell Stage widgets to the Home screens

Touch and hold your finger on an empty area on the Home screen to launch the widget manager.

To move an item such as a shortcut or widget, touch and hold the item, and then drag it to the new location.

To delete an item, touch and hold the item, and then drag it to the trash icon .

To add a widget, shortcut, or folder, touch and hold your finger on an empty area on the Home screen, and then touch the desired option.

Launcher

The Launcher displays all the available applications on your tablet, including any applications that you download and install from Android Market or other sources.

To open the Launcher, touch the Launcher icon  on the Home screen.





To open an application, touch the application's icon.

To create a shortcut to an application, touch and hold the application's icon until the tablet vibrates, and then drag it to another location on any screen.

Status Bars



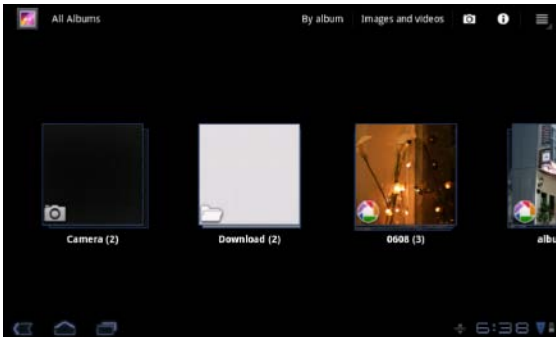

Action Bar — The Action Bar resides at the top of the screen and gives access to contextual options, widgets, and more. The Action Bar is controlled by the active application.

System Bar — The System Bar resides at the bottom of the screen. It displays notifications and system status. The Back , Home , and Menu navigation  keys are available in the System Bar.





Connect to a Wi-Fi Network

To connect your tablet to a Wi-Fi network:

1. Touch Home  → Launcher  → **Settings**.
 2. Touch  **Wireless & networks** → **Wi-Fi** to select the Wi-Fi check box.
The device scans for available wireless networks.
 3. Touch **Wi-Fi settings**. The names and security settings of available Wi-Fi networks are displayed in the **Wi-Fi networks** list.
 4. Flick the **Wi-Fi networks** list and touch the name of the network that you want to connect to.
 5. Type the password and other credentials (if required) and then touch **Connect**.
-  **NOTE:** When your device is connected to a Wi-Fi network, the Wi-Fi icon  appears in the system bar.

Add Your Gmail Contacts

To add your Gmail contacts to the Contact list on your tablet:

1. On the Home screen, touch the Launcher icon  → **Contacts**.
2. Touch Menu  → **Accounts**.
3. In the **Accounts & sync** screen, ensure that you select the **Auto-sync** and **Background data** check boxes.
4. Ensure that you are connected to the Internet and touch **Add account** → **Google Accounts**.
5. Enter your Google account login details and touch **Sign in**.
Your Gmail contacts are automatically added to your **Contacts** list.

The Gmail account you added appears under the **Manage accounts** section in the **Accounts & sync** screen.

Connect and Synchronize With a Computer

The Dell Mobile Sync software allows you to copy and synchronize music, photos, videos, and Outlook contacts between your tablet and a computer.

To install the Dell Mobile Sync software on your computer:

1. Connect the 30-pin-to-USB cable to your tablet and your computer.

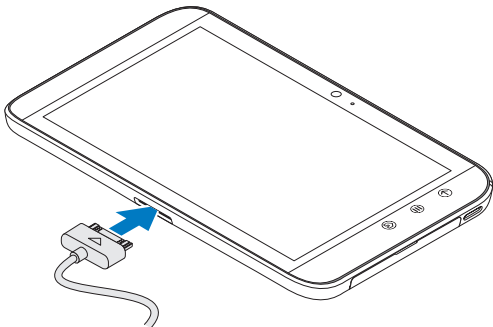

2. Obtain and install the drivers using one of the following methods:

- On your computer, find the file named **Drivers.zip** on the removable drive that represents the internal tablet storage.
- Download the driver from support.dell.com/support/downloads.

3. If the Dell Mobile Sync installer does not start automatically:
 - a. Double-click the new **Removable Disk** that appears on your computer.
 - b. Navigate to the **Dell Mobile Sync** folder on the removable disk.
 - c. Double-click the **InstallDellMSync.exe** file to start the installation.

 **NOTE:** You can also download and install the Dell Mobile Sync software from support.dell.com/support/downloads.

To sync music, photos, videos, and Outlook contacts:

1. Connect the 30-pin-to-USB cable to your tablet and your computer.
2. Double-click the Dell Mobile Sync icon  on the Windows desktop. Your tablet appears under the **Devices** section in the Dell Mobile Sync software.
3. After copy or sync is complete, disconnect the 30-pin-to-USB cable from your computer and your tablet.

 **NOTE:** For more information about the Dell Mobile Sync software and instructions to synchronize your tablet using Wi-Fi, see the documentation included in the Dell Mobile Sync software.

More Information

To learn more about the features and settings available on your tablet, see the *User's Manual* available on the SD card on your tablet or at support.dell.com/manuals.

 **NOTE:** QuickOffice is preinstalled in the tablet.

To view the *User's Manual* available on the SD card, launch the QuickOffice application and then select **Memory card**.

Before Sending Your Tablet for Repair

The service technicians at the service center may reset your Dell tablet to factory settings to resolve the issue with your tablet. It is recommended that you back up your data using the **Backup & Restore** feature before you send your tablet for repair.